



2024 Pro Mod Rules

DISCLAIMER:

The rules and/or regulations set forth herein are designed to provide for the orderly conduct of racing events and to establish minimum acceptable requirements for such events. These rules shall govern the condition of all events, and, by participating in these events, all participants are deemed to have complied with these rules. *No expressed or implied warranty of safety shall result from the publication of or compliance with these rules and/or regulations.* They are intended as a guide for the conduct of the sport and in no way a guarantee against injury or death to a participant, spectator, or official.

The race director shall be empowered to permit reasonable and appropriate deviation from any of the specifications herein or impose any further restrictions that in his opinion do not alter the minimum acceptable requirements. *No expressed or implied warranty of safety shall result from such alterations of specifications.* Any interpretation or deviation of these rules is left to the discretion of the officials. Their decision is final.

On occasion when situations arise that are not covered by written rules, special rulings may be put into effect by the Series of Track Officials. Once such rulings are acted upon, they *may* be added to the existing rules and/or procedures.

Contact Info:

RUSH Racing Series Directors: Vicki Emig (724) 674-6100/Cell & Mike Leone (724) 967-2363/Cell
4368 US 422, Pulaski, PA 16143
724-964-9300 (phone)
E-mail: info@rushracingseries.com

Travis Harry (Competition Director): 814-676-9997 or 814-758-5737 (after 5 PM).
E-mail: travisharry1123@gmail.com

The following guidelines shall be considered the "Official Rules and Specifications" for all events sanctioned by the RUSH Pro Mod Series.

Econo Mods meeting the technical rules packages of Eriez Speedway, Raceway 7, and Sharon Speedway will be permitted to compete in the RUSH Pro Mod division with the following exceptions/notations:

- **Econo Mod racer cannot protest a RUSH Pro Mod engine; RUSH Pro Mod racer cannot protest an Econo Mod engine.**
- **Meet all RUSH Pro Mod Personal Safety Equipment standards and items listed under "Other Recommended" (see page 21-23)**
- **Holley 26-342 or Holley 26-343 float bowl vent tube check valve highly recommended (see page 9)**
- **Intrusion plates are required (see page 14)**
- **Bump stops will NOT be permitted (see page 14)**

Technical inspection and penalties /suspensions of Econo Mods will be the responsibility of individual tracks, with the exception of enforcement of the RUSH Pro Mod tire rule.

For Econo Mod Rules, refer to www.sharonspeedway.com, www.raceway7.com or contact each individual promoter.

Note: Econo Mod racers will not be eligible for RUSH membership or "Manufacturers Night" product giveaways.



Pro Mod Championship Series

"Weekly Series Championship": Must be a Weekly member to be eligible for points and point fund monies. Drivers can compete at any RUSH-sanctioned event and accumulate points. Drivers best 12 point scores from throughout the season will be utilized.

Weekly Series Point Fund (\$15,050): 1. \$3,500 2. \$2,000 3. \$1,200 4. \$1,000 5. \$900 6. \$800 7. \$700 8. \$600 9. \$500 10. \$400 11. \$390 12. \$380 13. \$370 14. \$360 15. \$350 16. \$340 17. \$330 18. \$320 19. \$310 20. \$300

"Futures Cup" presented by 3C Graphix (\$300 to-win; other positions TBA on participation): Must be a Weekly member, not be older than 19 years of age (cannot turn 20 before July 1) , and not be a prior "Futures Cup" Champion to be eligible for points and point fund monies. Those 18 & 19 cannot have more than 1 prior season of E-Mod, Econo Mod or Crate Late Model experience (8 or more events = 1 season). No headlining division experience permitted. Those under 16 should verify eligibility to race at each individual track. Points are based off Weekly Series Championship plus the addition of possible stand-alone TBA event(s).

Point Fund Clause: In the event of unforeseen circumstances, the RUSH Racing Series reserves the right to adjust any and all point funds.

"Manufacturers Night" presented by MSD Performance: A Manufactures Night will be held at a location and date TBA where several thousands of dollars of products will be given away. Driver's car MUST be 100% RUSH legal and attempt to compete in the night's racing program.

Point System: The following system will be utilized for all of the above programs: 1. 100 2. 98 3. 96 4. 94 5. 92 6. 90 7. 89 8. 88 9. 87 10. 86 11. 85 12. 84 13. 83 14. 82 15. 81 16. 80 17. 79 18. 78 19. 77 20. 76 21. 75 22. 74 23. 73 24. 72 25 & any other starter 71. Drivers attempting to race, but not starting the feature will receive 70 show-up points. Note: Excluding the Touring Series, at each event drivers will receive a car count bonus of 12 points provided

there are 12 or more cars signed in. If there are less than 12 cars, the car count bonus will be based on number of competing cars signed in.

Postponed feature events will revert back to the weekend they were initially scheduled for with the exception of an event that has been pushed to the following year.

Membership Fees: \$125 to become a Weekly Series Member. MUST be a member to be eligible for above programs and \$100,000 excess participant accident insurance. Policy period is 1/1/24-1/1/25; however, coverage does not begin until membership is completed and paid. RUSH insurance benefits will cover the member driver after the tracks participant accident limit and driver's individual health insurance benefits are exhausted, but only at RUSH-sanctioned events.

POINTS ARE NOT RETROACTIVE. YOUR POINTS WILL NOT COUNT UNTIL MEMBERSHIP IS COMPLETED & PAID! Drivers that do not wish to become RUSH members, MUST complete the Non-Member Registration. Membership Forms are available at the following link <https://rushpromods.com/memberships.html> or can be purchased through the Pit Pay App <https://getpitpay.com/5lb>.

RUSH reserves the right to decline a membership or revoke a membership at any time.

Awards Banquet/Point Funds/Tie-Breakers: A RUSH Racing Series Awards Banquet will be held at the conclusion of the season (mid to late January). Drivers/Car Owners are expected to attend or have a pre-determined representative to accept awards. Unclaimed payoffs and awards will be mailed at a later date.

In the event of a tie for the Weekly Series or Futures Cup Championships, tiebreaker will be determined by the driver with the most high point scores followed by most second high point scores, etc. until the tie is broken (in essence most 112's, most 111's, most 110's, etc). If a tie happens in any other position, the tie will remain with point fund monies added up between the tied positions and split equally.

AGE REQUIREMENTS:

Age requirements vary by speedway. It is the team's responsibility to verify eligibility regardless if it's a Touring Series or Weekly Series event.

PAYOFF:

While the RUSH Series makes every effort to sanction and/or schedule events at reputable facilities, and has never had any problems with purse payouts to competitors, please be aware that RUSH cannot be responsible in the event that a promoter fails to make purse payments, or pays with checks which are later found to be not negotiable. This notice includes the possible situation where a promoter might pay the full purse to RUSH with a check that is later to be insufficient. RUSH will not pay purse payments until promoter's check clears. When speedway and/or promoter's check clears, RUSH will then guarantee proper purse payments, subject only to resolution of protests, or technical infractions.

RUSH Series Officials reserve the right to hold payoff(s) of driver(s) selected for technical inspection(s). Payoffs will only be released to 1099 recipient(s) of selected driver(s) upon final technical inspection results and/or appeal process providing said inspection complies with RUSH Technical Rules. In the event selected driver(s) technical inspection results does not comply with RUSH Technical Rules and appeals process has been exhausted, said payoff will be adjusted and distributed to other competing racers.

RUSH Series Officials also reserves the right to withhold a driver's payoffs in the event said driver has a debt to the Series.

RUSH will mail the person or corporation designated on the membership form any purse or point fund payoffs. In the event of a car owner change, a new membership form must be completed. In the event of a car owner change midseason, point fund payoffs would be prorated based on performance (based on the program's specs, i.e. best 12 finishes) in all point funds other than Touring, which has a separate driver/owner point fund. A Form 1099 MISC by

January 31 of the following year will be sent to the person or corporation that earned a minimum of \$600.00 during the year for any monies paid by Great Crate Racing Northeast, LLC D/B/A RUSH Racing Series, as required by the IRS.

SERIES' SPONSOR PRODUCT CONTINGENCIES AND DECALS:

The RUSH Pro Mod Series decal is required on both sides of the car. Sponsor decal package/logos link for body graphics usage is located at the bottom of the website sponsor page.

Required RUSH Series sponsor decals must be displayed prominently on both sides of the car at all events. Your car may be checked for decals at any time.

Certain product manufacturers award contingency product and/or money. The awards are dependent upon the manufacturers decal being displayed on the racecar. To be eligible to receive the award from the manufacturers concerned, it is your responsibility to ensure that the correct decal is affixed to your racecar.

Please be aware that the Series' has no responsibility to pay the award, but only to provide the participant with the certificate previously agreed upon and contracted with the Manufacturer.

Contingency prizes will be awarded to the car owner of record. It is the responsibility of the participant to redeem contingency prize certificates and/or product by expiration date on certificate. Series will not be responsible for delivery and/or transportation of contingency prizes that were not available for pick-up on event date.

Keep in mind that sponsors only put money into the Series to gain exposure for their products; no exposure will eventually mean no money and smaller championship programs.

RUSH Racing Series Officials may refuse to allow a participant to compete in an event if it is determined at their discretion that any advertising and/or sponsorship or similar agreement is **detrimental** to the sport, the RUSH Racing Series, or the event promoter for any reason, including the image of the sport.

CONDUCT:

At RUSH Weekly Sanctioned events, the racing procedures and track conduct will be administered and enforced by track management and officials.

1. All drivers, crew chiefs, car owners, crew members and/or team representatives agree to act in a professional manner as determined by RUSH Officials. The professional manner includes, but is not limited to verbal representation, written representation, any representation that may represent the RUSH Racing Series, sport of Late Model racing and/or motorsports in general and/or any affiliates. Verbal and/or physical abuse towards a RUSH Series Official may result in an immediate disqualification and/or fine and/or suspension and/or legal action and/or other action deemed appropriate by RUSH Series Officials.
2. Any driver or car owner that disparages RUSH in any publication, including all forms of social media and public forums may be subject to a fine and/or suspension and/or legal action and/or any other action deemed appropriate by RUSH Series Officials.
3. Any driver, during an event; a competitor, crew chief, car owner, crew member and/or team representative may be requested to report for consultation and/or technical inspection with RUSH Officials. The request may be communicated over the one-way radio and/or verbally. Failure to comply with the request will be subject to disqualification, possible fine and/or suspension and/or any other action deemed appropriate by RUSH Officials.

Participants grant and assign to RUSH Racing Series, its affiliates and RUSH Racing Series Sponsors the non-exclusive rights and authority to use my image and likeness, including my name, nickname, initials, picture, photograph, animation, persona, autograph/signature (including facsimiles thereof), voice, biographical information, and/or any and all other identifying characteristics, including the image of my vehicle, whether portrayed in still or action pictures, drawings, or other artistic renderings, in connection with my participation in RUSH Racing Series Events and for any and all uses or

purposes that publicize and promote RUSH Racing Series or any of its affiliates in any way in any and all media or formats.

ENVIRONMENTAL WARNING:

1. **Any driver or crewmember** found to be altering, by means of contaminating the racing surface or pit area or racing entrances and/or staging or technical inspection areas or **ANY** part of the event grounds or properties and nearby driveways will be **disqualified**. The local authorities and/or agencies may be notified and the violator(s) and their information may be turned over to these authorities at that time.
2. **No race cars or vehicles** including, but not limited to **race trailers**, or **support vehicles** or **trailers** will be allowed to carry or conceal, in marked, unmarked or using any form of misrepresentation of jugs or bottles or carrying devices of any type (with concerns to chemicals), for the purpose of altering, conditioning or changing a tire's baseline settings (from its original factory set baseline settings) will be allowed in or around the/any RUSH Series Event/s. All local authorities and applicable agencies may be called and the violators and their information will be turned over to these authorities at that time.

TECHNICAL RULES & REGULATIONS

It is ultimately the obligation of each participant to ensure that their conduct and equipment complies with all of the applicable rules, as they may be amended from time to time; any amendments supersede any previous rules regarding any technical and/or aspect. An amendment is effective upon the date of the publication of the amendment regardless of when a competitor receives the actual notice.

Any new components, including engine components, suspension components, body designs, frame designs and/or components of any type utilized in competition must be approved by RUSH Officials prior to being introduced into competition.

ENGINE:

1. GM part number 19370602, 19258602, 88958602, 19418602, 19431602, 19432602 or 19433602 & GM part number 19318604, 88958604, 19370604 or 19433604; RUSH reserves the right to amend this list of approved engine part numbers.
2. All engines are to remain sealed from the factory. These engines are sealed at the intake manifold, cylinder heads, front cover, and oil pan with special GM twist-off bolts or cap seals. The original factory seals (bolt type or cap seals) must remain unaltered. Tampering, removal, or modifications of any type and/or broken factory seals, bolt type or cap seals type, will not be permitted and will result in an immediate disqualification from the event (loss of points and money). The engine may be impounded immediately for further inspection.
3. The exception to this will only be if a repair or rebuild is required. The repair/rebuild must be authorized by the RUSH Racing Series and/or Crate USA, at which time the engine may be repaired or possibly rebuilt per the guidelines set forth in the GM Technical Manual #88958668. Crate engines must not be altered, modified, or changed from factory specs, unless any such alteration, modification or change is approved by RUSH. RUSH Authorized Rebuilders will be notified of any such alteration, modification or change.
4. In the event of a repair or rebuild only a RUSH or Crate Racin' USA authorized rebuilder facility may install permitted seal tags on engine. RUSH Seals and Crate USA Generation V (black), Generation IV (green), Generation III (yellow), and Crate USA Gen V (light blue) seals permitted.

RM bolts, American Crate All Star Series (ACAS), DIRTcar, FASTRAK, NDRA, Crate USA Generation I (silver) or Crate USA Generation II (blue - Tyden Brooks) seals are NOT permitted. To compete with any other sealing system, contact RUSH for approval.

5. Engines "must" be sealed in all of the above stated locations with either the "original" GM twist off bolt heads or cap seals, RUSH seal tags, or a combination of the "original" GM twist off bolts or cap seals and/or RUSH seal tags.

6. The sealed engines must remain intact and not be tampered with; **any seals** that have been tampered with, removed, or modified, and/or broken will make the engine illegal and will result in an immediate disqualification from the event (loss of points and money). The engine may be impounded immediately for further inspection. Modifying any internal engine parts or changing the parts from stock as delivered sealed from the factory, other than those approved by RUSH, will result in disqualification for the night's event (loss of points and money), loss of all Series points to date in the division the infraction occurred in, suspended from all RUSH-sanctioned Series competition for 365 days, fined \$1,000, and an indefinite probation.
7. In the event a repair must be made to an engine scheduled to compete in consecutive RUSH-sanctioned events or if RUSH seals cannot be obtained in time for competition in a single event, engine owner and or competitor "must" have authorized RUSH engine rebuilder of their choice contact RUSH Series Directors to receive permission and instructions on obtaining "approved" temporary seals in order for engine to compete. RUSH Competition Director can also install "approved" temporary seals in this situation. Temporary seals will "only" be permitted on repaired engines for events that are designated by RUSH Series Directors. Note: Once temporary seals are removed from engine, they must be immediately returned to the RUSH Racing Series Office.
8. The permitted GM factory sealed crate engines must not be altered, modified, or changed from the GM specifications set forth in the GM Technical Manual #88958668; no changes are allowed to the engine- intake manifold, heads, valve covers, front cover, oil pan, harmonic balancer, or any other part or parts on or in the engine. Any alteration, modification or change must be approved by RUSH. RUSH Authorized Rebuilders will be notified of any such alteration, modification or change.
9. Valve spring shimming to meet the required correct install heights listed on the GM 604 charts below is permitted; *shimming of GM 602 valve springs is **not** permitted.*

604 Valve Spring Specifications – New		
Description		
Valve Spring P/N		12551483
Valve Spring P/N -set of 16		12495494
Diameter (+/- .010")	(A)	1.340"
Free Height (+/- .015")	(B)	2.154"
Installed Height (<i>Ok to shim to proper height</i>)	(C)	1.780"
Pressure @ Installed Height (+/- 5 lbs)	(D)	110 lbs.
Open Height	(E)	1.300"
Open Pressure (+/- 10 lbs)	(F)	270 lbs.
Coil Bind	(G)	1.21"
Wire Diameter		.178"

602 Valve Spring Specifications – New		
Description		
Valve Spring P/N		10212811
Valve Spring P/N -set of 16		n/a
Diameter (+/- .010")	(A)	1.250"
Free Height (+/- .015")	(B)	2.021"
Installed Height (<i>Shimming of valve springs NOT permitted</i>)	(C)	1.70"
Pressure @ Installed Height (+/- 5 lbs)	(D)	80 lbs.
Open Height	(E)	1.270"
Open Pressure (+/- 10 lbs)	(F)	195 lbs
Coil Bind	(G)	1.20"
Wire Diameter		.177"

10. Beehive Valve Springs:

Valve Spring Specifications – Beehive Valve Spring		
Description	Engine	'604
Valve Spring P/N -16		19420455
Diameter Top (+/- .008")		1.060"
Diameter Bottom (+/- .008")		1.270"
Free Height (+/- .015")		2.122"
Installed Height (<i>Ok to shim to proper height</i>)		1.780"
Pressure @ Installed Height (+/- 5 lbs)		98 lbs.
Open Height		1.300"
Open Pressure (+/- 13 lbs)		264 lbs.
Coil Bind		1.210"
Wire Diameter		Ovate

11. No vacuum pumps.
12. Engine's GM serial number and when applicable RUSH or Crate USA build certification number must be clearly visible to Series' or track technical inspectors.
13. RUSH Racing Series Officials reserve the right to inspect, exchange and/or confiscate any GM Crate engine, or other specified engine component. In the event the engine or specified component is to be removed, it must be removed immediately by person(s) appointed by driver and/or car owner. Refusal to surrender an engine or other engine part for inspection, exchange or confiscation, will result in disqualification for the night's event (loss of points and money), loss of all Series points to date in the division the infraction occurred in, suspension from all RUSH-sanctioned Series competition for 365 days, fined \$1,000, and an indefinite probation; penalties apply to both driver and car owner.
14. ANY VIOLATION OF THE ENGINE RULES AND/OR FACTORY SPECS INSIDE THE SEALING SYSTEM OF THE ENGINE WILL result in disqualification for the night's event (loss of points and money), loss of all Series points to date in the division the infraction occurred in, suspension from all RUSH-sanctioned Series competition for 365 days, fined \$1,000, and an indefinite probation; penalties apply to both driver and car owner.

After the suspension period, the driver and/or car owner can only compete in Series events with an engine equipped with original factory GM sealing bolts or cap seals, RUSH, and/or permitted Crate USA seals.

For subsequent violations in regard to any illegal modification to any GM Performance Parts Crate Engine, an indefinite suspension may be issued.

15. Any violation of the engine rules and/or factory specs outside the original GM twist off bolt heads or cap seals and/or permitted Series seal tags on the engine will result in the driver and car being disqualified from that event (loss of points and money). Multiple infractions outside the sealing system will result in the penalties stated in the "Multiple Infractions" section of the rules.

ENGINE SETBACK:

1. Rear of engine, bell housing mounting flange surface, must be mounted at least 72" forward from the centerline of the rear axle. The engine offset must remain within two ("2") of the centerline of the cross member. The minimum engine height when measured from the ground to the center of the crankshaft is 11".

ENGINE PROTESTS/SELECTION:

1. Any RUSH-sanctioned race track and/or RUSH Series Director(s) are authorized to call for an engine inspection or tear down *at any time*. Inspection and tear down will be performed by RUSH Tech/Competition Director. Person(s) appointed by driver and/or car owner will remove engine immediately at race track and track/Series will impound engine until inspection day can be arranged for all parties involved. (See paragraph number six for procedures if selected car is to race in successive events.)
2. The protest fee for a complete teardown of an engine that finishes the A main in the top five is \$2,000, and must be made by a driver/owner that finishes in the top five. \$300 of protest fee will go to Series or Track and the remaining \$1,700 will go to the winner of the protest.
3. The protest fee for a partial teardown of an engine that finishes the A main in the top five is \$1,500, and must be made by a driver/owner that finishes in the top five. \$300 of protest fee will go to Series or Track and the remaining \$1,200 will go to the winner of the protest. A partial teardown will include the following: cam profiled along with the timing components, lifters, and cylinder heads verified.
4. Protest and fee in cash must be made to a RUSH Tech Inspector, Race Director, or Track Tech Inspector within 15 minutes of the checkered flag of the feature. Protest cannot be withdrawn once it has been declared. Protested competitor cannot counter-protest in the same event.
5. At any time an engine is protested and driver/car owner accepts protests and agrees to tear down, the engine being protested must be removed immediately by person(s) appointed by driver and/or car owner and impounded by Series/Track. Protested engine will be sealed by RUSH Official or person(s) appointed by RUSH to insure that it has not been tampered with, and to verify engine's identity. Any refusal to permit engine confiscation will result in disqualification for the night's event (loss of points and money), loss of all Series points to date in the division the infraction occurred in, suspension from all RUSH-sanctioned Series competition for 365 days, fined \$1,000, and an indefinite probation; penalties apply to both driver and car owner.
6. *If the protested car wishes to race in successive RUSH-sanctioned events within 72 hours (three days) the following will apply ONLY at the discretion of RUSH:* RUSH Series Officials reserve the right and also grants the right to RUSH-sanctioned speedway tech officials to seal or otherwise identify the protested engine to allow the car to compete in successive events within 72 hours (three days). Further postponement of tear-down will be at the discretion of RUSH Directors/Officials. The driver and/or owner has the option whether to surrender the engine on the night it's protested or have it identified and retained for the successive races. However, if the driver chooses to compete with the engine after its selection for tear down, and that engine is found to be out of compliance with RUSH Technical/Engine rules, the driver will be disqualified from all races entered after the engine was protested, in addition to the race when engine was protested. RUSH *may* assess penalties for *each* race in which the selected engine was used after its selection, if it is found to be illegal. If the engine is found to comply with all applicable rules, then driver/owner will be awarded all money and points earned for each event.
7. At this time, the feature finish will be frozen until inspection is complete. In the event of a disqualification, finishing position, points and monies would be adjusted accordingly.
8. Failure and/or refusal to tear down an engine and/or for your race car to be inspected by Series at any time will result in disqualification for the night's event (loss of points and money), loss of all Series points to date in the division the infraction occurred in, suspension from all RUSH-sanctioned Series competition for 365 days, fined \$1,000, and an indefinite probation; penalties apply to both driver and car owner.
9. Inspection location will most likely be at RUSH office/garage located at 4368 Route 422, Pulaski, PA 16143. Although other inspection locations could be selected. There will be no dispute over RUSH Official's choice of location.
10. Driver and/or car owner and one other representative of the team will be allowed in the tech area during the engine teardown. Only one representative from the team protesting the engine will be allowed in the tech area during the engine teardown. Additional attendees must be approved by RUSH pursuant to a written request. Protestor and protested driver and/or car owner along with the confiscated sealed engine and/or parts must be present at predetermined location. All parties must remain present during the entire teching procedure.

11. Note: All removed original GM bolts or cap seals, RUSH and/or CUSA Seals must be returned immediately to the RUSH Office.
12. Engine infractions "within the bolts" will result in disqualification for the night's event (loss of points and money), loss of all Series points to date in the division the infraction occurred in, suspension from all RUSH-sanctioned Series competition for 365 days, fined \$1,000, and an indefinite probation; penalties apply to both driver and car owner.
13. In the event that the series confiscates engine, for inspection, and said engine is found to be legal, and comply with the all the rules, the "Series" will provide a full GM gasket set, and the seals to reassemble engine at no charge to the authorized rebuilder and engine owner. If engine is protested by another racer for inspection, the engine owner is responsible for all expenses required for reassembly.

CARBURETOR:

1. One four-barrel carburetor only. The 604 and 602 Chevrolet Performance Circle Track engines perform best with a quality 650 CFM Carburetor. Any 750 CFM or smaller carburetor allowed; must have 1 11/16" base plate maximum.
2. All carburetors in competition must retain conventional style floats along with needles and seats. Maximum allowed fuel pressure is 12 psi.
3. All carburetors must have conventional Holley-style straight or down leg boosters; no exceptions.
4. Holley 26-342 or Holley 26-343 float bowl vent tube check valve is highly recommended.
5. Engine must be naturally aspirated.
6. **604** - May use one carburetor spacer (1" - one piece with 0.040" tolerance maximum) and two standard paper gaskets (maximum 0.070" thick), one gasket between intake to spacer and one gasket between spacer to carburetor.
7. **602** - May use one carburetor spacer (2" - one piece with 0.040" tolerance maximum) and two standard paper gaskets (maximum 0.070" thick), one gasket between intake spacer and one gasket between spacer to carburetor.
8. Pipe plugs must remain in manifold heat crossover port on GM 602 crate engines.

EXHAUST:

1. Collector-type headers required. Must have four (4) tubes into one (1) collector of a consistent diameter.
2. NO tri-y headers, merged headers, or square-tube headers allowed.
3. Headers may dump outside of engine or rear of engine and must not point directly to the ground.
4. Mufflers not required unless track mandates. *When mandated, mufflers must have some type of internal noise dampening characteristics, baffles, extruded holes, screen, chambered, etc.* Mufflers must be securely attached. *Mufflers must meet local speedway's noise decibel requirements. External mufflers only.*

DISTRIBUTOR/IGNITION:

1. Any electronic distributor-type ignition system. NO crank trigger, distributor less multi-coil, or magneto ignition system. **(Option: GM HEI-style, any brand MSD 8365 permitted.)** No programmable ignition box. Only one ignition box permitted. Dual pickup distributor permitted; only one pickup in distributor can be utilized.
2. Competitor may be asked for electronic ignition at any time to be sent for testing and inspection. Failure to relinquish electronic ignition will result in disqualification and "refusal of tech" penalties.

BATTERY/STARTER:

1. Battery must be securely mounted, shielded, and fastened with positive fasteners and brackets across the top. Battery must not be mounted inside the driver's compartment.
2. The battery terminals must be insulated and enclosed with a non-conductive material that will prevent contact with any part of the race car should the battery become dislodged from the battery mount.
3. All battery supports and/or mounts must be secure and braced in two (2) horizontal positions and one (1) vertical position.
4. No lithium batteries.
1. One (1) mandatory battery disconnect switch must be installed on the rear deck, behind the driver seat, in a location that is easily accessible from the "outside" of the race car. The switch must be clearly labeled with off/on direction. The switch must be directly in-line with the NEGATIVE battery cable and be capable of completely disconnecting the NEGATIVE terminal of the battery from the race car. Negative or "ground" wiring connections must not be made anywhere from the battery negative terminal to the input side of the disconnect switch. Negative or "ground" wiring connections must "not" be made anywhere from the battery negative terminal to the input side of the disconnect switch. An additional battery disconnect switch within the driver's reach may also be used.
5. All cars must have a starter in working order

Gauges and Dash Modules:

1. Gauges to monitor engine conditions are permitted but will be limited to the following;
 - Oil pressure
 - Oil temperature
 - Engine coolant pressure
 - Engine coolant temperature
 - Fuel pressure
 - Battery voltage
 - Engine RPM
2. All electronic gauges whether analog or digital, except tachometers, will only be permitted to have one (1) input from the respective gauge sensor. Outputs from the gauges will not be permitted. Tachometers will be permitted to record engine RPM for recall and playback.
3. When an electronic dash module is used in lieu of individual gauges, only the inputs as described above for individual gauges will be permitted. All other input channels must be disabled and blocked off from usage. Only engine RPM may be recorded. Wiring to the electronic dash module must be accessible and removable for ease of inspection.
4. All additional wiring harnesses related to electronic dash modules or any other type of data acquisition must be completely removed from the race vehicle during an event.

FUEL/FUEL CELL/FUEL PUMP:

1. All cars must have fuel cells that meet and/or exceed FIA/FT3 or SFI 28.3 specifications. The fuel cell must not exceed a 32-gallon capacity.
2. Fuel cell cap must be a threaded cap and/or ATL Part #TF751 1/4 Turn Bullet Cap, Schultz Racing Fuel Cell Parts #SFP-300 1/4 Turn Cap or similar 1/4 turn fuel cap.

3. Fuel cells must be enclosed completely in a steel container, and mounted behind the rear axle, and must also be protected in rear by roll cage tubing mounted securely to the frame or rear bumper. Fuel cell may not be lower than protective tubing. Fuel cell must be completely visible.
4. All fuel cells must be mounted securely to the frame. behind the rear axle between the rear tires, and a minimum of 4" ahead of the rear bumper, using a minimum of two bars around the top, bottom, and sides of the fuel cell. The fuel cell must be mounted with a minimum of two (2) .125" inch thick, 2" minimum width steel straps. Straps must fully encircle the fuel cell. Fuel cells that are mounted in a square tubing frame will be permitted. A minimum of 7/16"-inch ASTM Grade 8 bolts must be used to mount the fuel cell to the frame.
5. No part of fuel cell should be lower than the protective tubing. Protective tubing should extend no wider than 6 inches on both sides of fuel cell.
6. The fuel pickup must be positioned on the top of the fuel cell, and be constructed of steel. The fuel pick-up must have a check valve, and bladders are highly recommended. Bottom feed or vertical side pickups are not permitted. The fuel pickup must have a check valve. Pickups on vertical sides prohibited.
7. For the purpose of inspection, the driver and/or crew must be prepared to drain fuel upon request for inspection and/or measurement.
8. RUSH 91 pump fuel is the only permitted fuel. **It is the racers' responsibility to know what he or she is putting in the fuel cell.**
9. Series reserves the right to check fuel anytime. Three samples will be taken by RUSH or a RUSH appointed Track Official. Each sample will be identified as sample #1, sample #2, and sample #3. Sample #1 will be retained by Series and sent to lab; sample #2 will be given to selected fuel's driver/owner; and sample #3 will be retained by Series to be utilized as a tie-breaker in the event any issues may occur with samples #1 & #2. Fuel samples not conforming to RUSH Pro Modified Series Fuel rule will be deemed illegal.
10. Series Officials may amend the fuel rule for any event, and will inform competitors.
11. **PENALTIES FOR FUEL VIOLATIONS:** Disqualification from event (loss of points and money) in addition to the following penalties:
 - First Offense: \$500 fine & 30-day suspension from any RUSH-sanctioned event plus all related lab testing costs.
 - Second Offense: \$1,000 fine & 90-day suspension from any RUSH-sanctioned event plus all related lab testing costs.
 - Third Offense: \$2,000 fine & 365-day suspension from any RUSH-sanctioned event plus all related lab testing costs.

ALL DECISIONS ARE FINAL!

12. Mechanical fuel pumps only; cam driven or belt driven style. Regulators permitted. Fuel injection system(s) and/or electrical fuel pumps and/or any type of pressurized fuel system will not be permitted.

TIRES:

The following are permitted:

- Hoosier 26.5/8.0-15 or 27.5/8.0-15 Medium 100's or Medium.
- Hoosier 26.5 8.0 15 SCL M30S or 27.5 8.0 15 SCL M30S

RUSH Series Officials may amend the tire rule for any event if track conditions and/or unforeseen circumstances warrant, and will inform competitors.

Tires not conforming to manufacturer's submitted factory benchmark will be deemed illegal.

WARNING: RUSH and Hoosier Racing Tires strictly forbids any chemical alteration of the tire carcass and/or tread compound such as tire soaking or use of tread "softener". RUSH and Hoosier Tire strictly forbids the physical defacement (removal, altering, or covering) of tire sidewall markings in any manner. Failure to comply with this warning could result in premature or catastrophic tire failure and may result in serious injury or death.

RUSH or RUSH appointed Track Officials may take physical samples to insure that no competitor has employed any chemicals to alter the performance of his or her tires at any time during the event for later submission to an independent laboratory.

Three samples will be taken per selected tire; samples will be taken by RUSH or RUSH appointed Track Official. Each sample from selected tire will be identified as sample #1, sample #2, and sample #3. Sample #1 will be retained by Series and sent to lab; sample #2 will be given to selected tire's driver/owner; and sample #3 will be retained by Series to be utilized as a tie-breaker in the event any issues may occur with samples #1 & #2.

Tire samples not conforming to manufacturer's submitted factory benchmark will be deemed illegal. Results are the sole property of RUSH. Driver and/or car owner will be notified of results, and in writing if tire sample(s) do not match the factory benchmark.

It is the driver's responsibility to know what is on their race car at all times. Any used wheels or tires that may be suspect by the driver should not be used. The driver, owner and/or appointed team representative may be in the tech area to view what is being tested.

Any tire thought to be physically defaced or altered will be confiscated. While tire is in question, all money and points for that driver will be held until a ruling is made final. Any tire deemed to have been physically defaced or altered will result in disqualification from the event (loss of money and points) along with the following:

PENALTIES FOR ILLEGAL TIRES:

- First Offense: \$500 fine & 30-day suspension from all RUSH-sanctioned events plus all related lab testing costs.
- Second Offense: \$1,000 fine & 90-day suspension from all RUSH-sanctioned events plus all related lab testing costs.
- Third Offense: \$2,000 fine & 365-day suspension from all RUSH-sanctioned events plus all related lab testing costs.

Failure to allow any tire(s) to be confiscated will result in additional \$500 per tire fine in addition to any other fines and penalties. All decisions are final.

Only one-piece 8" maximum steel production racing wheels will be permitted. [Beadlocks permitted on the outside of the wheel only; aluminum beadlock rings permitted.](#)

WHEEL COVERS: Wheel covers: Only steel wheel cover fasteners permitted. It is highly recommended that wheel covers have a minimum of 5 mounting points. However, 5 and 3 mounting point wheel covers will be allowed for competition under the following conditions: Wheel covers having a minimum of 5 attachment points may continue to use steel dzus fasteners. Dzus fasteners must be made of steel only. Wheel covers having only 3 attachment points must be bolted-on at all 3 points utilizing a minimum 1/4" or 5/16" magnetic steel hex head bolt and an approved fastening (nut assembly) system.

Approved fastening (nut assembly) systems:

1. Precise Racing Products Part # WCBK
2. Keyser Manufacturing Part #100 7-101.
3. Wehrs Manufacturing Part # WM377A-312 Aluminum 5/16" / WM377S-312 Steel 5/16"
4. Triple X Chassis Part # SC-WH-7810(for a 1" spring) / SC-WH-7820 (for a 1 3/8" spring)
5. Smith Precision Products Part # MC-516-18

Optional fastening systems that are equal or superior to the above-approved system will be readily approved at the sole discretion of Technical Officials.

SHOCKS: Only RUSH Series shocks by Bilstein may be used in competition at any location on the race car. Only one shock absorber is allowed per wheel. If a shock absorber is used to dampen rear end movement it must be located at minimum 12" from any part of either rear brake rotor and must be chosen from the following list of shock part numbers.

The only Bilstein shock absorber part numbers that may be utilized are listed below. Note: they may be used on any location on the car.

- RUSH RF 9-3,
- RUSH RF 7-3,
- RUSH RF 12-2,

- RUSH LB 5-3, CR USA LB 5030, (These two shock part numbers are the identical shock and valving except for the part number.)
- RUSH RR 3.5-1.5, CR USA RR 3.5-1.5, (These two shock part numbers are the identical shock and valving except for the part number.)
- RUSH LRB 3-6, CR USA LRB 3-6 (These two shock part numbers are the identical shock and valving except for the part number.)

- RUSH LR 1.5-7.5

- RUSH PB 2-6

Shock covers permitted, but must be removed for all technical inspections.

Shocks may not be altered in any way; shock shafts may not be shortened nor strategically bent to seek a handling advantage, gas pressure must not have been altered, and no tampering with the pistons, seals, oil, shock body or valve stack is allowed. RUSH competitors agree to willingly relinquish any one or all shock(s) from any position or all positions on his or her race car that comes into question to RUSH Series tech officials for dyno testing and inspection to determine whether it is, or is not, a legal, unaltered shock. Shock(s) confiscated for further testing will be tagged by a numbered wire seal with Bilstein part numbers and wire seals documented on an official RUSH Shock Confiscation form. Competitor must accept from tech officials a shock(s) of the same valving part number in return for the shock(s) relinquished.

If, upon dyno testing and inspection, it is determined that the gas pressure, seals, piston, oil, shock tube, rod, or valving has been altered in any way, the shock absorber will be determined illegal and RUSH published penalties will apply.

RUSH Racing Series Officials reserve the right to technically inspect, exchange and/or confiscate any specified Bilstein sealed shock at any time.

PENALTIES FOR SHOCK VIOLATIONS: Disqualification from event (loss of points and money) in addition to the following penalties:

- First Offense: \$500 fine & 30-day suspension from any RUSH-sanctioned event plus all related testing costs.
- Second Offense: \$1,000 fine & 90-day suspension from any RUSH-sanctioned event plus all related testing costs.
- Third Offense: \$2,000 fine & 365-day suspension from any RUSH-sanctioned event plus all related testing costs.

Remote Control Suspension Devices: No "in-cockpit driver controlled" suspension devices permitted. No weight jacks etc. of any kind. Any driver using "in-cockpit driver controlled" suspension devices or weight jacks will be disqualified from competition. A competitor found with a remote control suspension device will be disqualified from the event (loss of points and monies) and forfeit the device permanently,

SPRINGS: Only one spring is allowed per wheel. Progressive rate springs at the suspension locations are not allowed.

One additional spring will be allowed for use in a device used to control rear end rotation; this spring may have a progressive rate.

All coil springs must be 100% constructed from steel, no exotic metal alloys or composite spring technology will be allowed.

Leaf springs may be used in the rear and may be composite material or spring steel.

No torsion bars or airbags are allowed.

Spring rubbers are "not" permitted.

Rear springs must be a minimum of 4.5" i.d. Rear springs may be mounted on a coilover kit and the coilover kit may be made of aluminum or steel, no titanium or composite materials are allowed. Coilover eliminator devices must be all steel in construction.

BUMP STOPS: No bump stops permitted

DRIVER SIDE INTRUSION PLATE:

1. A minimum 1/8" (.125") thick **magnetic steel** intrusion plate on the driver's side door bars is mandatory.
2. Approved installation:
 - A. Welded plates- Individual plates between door bars are permitted but must be weld around the perimeter of each opening. Minimum area covered is 16 inches by 26 inches.
 - B. A minimum of 16" x 26" plate bolted to fabricated 1/8" (.125") magnetic steel tabs, welded securely to the chassis, using a minimum of eight (8) x 3/8" Allen button head bolts. A minimum of three (3) fabricated 1/8" (.125") magnetic steel tabs and 3/8" Allen button head bolts required across top of the intrusion plate, a minimum of three (3) fabricated 1/8" (.125") magnetic steel tabs and 3/8" Allen button head bolts required across the bottom of the plate, and one (1) fabricated 1/8" (.125") magnetic steel tabs and 3/8" Allen button head bolt in each in the middle front and middle rear of intrusion plate.
 - C. A minimum of 16" x 26" plate bolted to a minimum of six (6) approved-design door bar clamps using the included 12 x 1/2" Allen button head bolts per the manufacturer's specification. A minimum of three (3) approved-design door bar clamps and the included six (6) x 1/2" Allen button head bolts required across top of the intrusion plate and three (3) approved-design door bar clamps and included six (6) x 1/2" Allen button head bolts required across bottom of intrusion plate. Vendor and part number must be clearly labeled on part.

Current approved-design door bar clamps – in order of submission:

- Bicknell Racing Products – Part Number: BRP 9547
- Wehr's Machine & Racing Products – Part Number: WM397
- Allstar Performance – Part Number: ALL4198

- (No other manufacturer has submitted a design for approval at this time)

CHASSIS & FRAME

1. Only factory production full 1965 or newer parallel American passenger car frames will be permitted. The frame must be complete in front of the firewall. Cutting of the frame in any way in front of the firewall will not be permitted.
2. The frame must remain unaltered.
3. Wheelbase: Minimum 108", maximum 112". No tolerance.
4. The right-side frame rail may not be altered or moved from the stock OEM location with the exception that the right-side frame rail may be raised behind the front clip a maximum of 2" from the OEM location.
5. Frame rails may be a maximum of 6" from the ground to the bottom or the lowest edge of the left side frame rail and may be a maximum of 8" from the ground to the bottom of the lowest part of the right-side frame rail.
6. The front cross member may be notched to allow clearance for the radiator only; 3" minimum for notching is required. The cross members must be plated to retain complete box configuration.
7. Jeep, Bronco, 4-wheel drive, front wheel drive or sports car frames will not be permitted.
8. Frame may not be widened or narrowed and must be able to support the roll cage on both sides and must be full and complete on both sides.
9. The minimum ground clearance for the frame/body will be 4".
10. The front bumper must be mounted to the ends of the frame with the bottom loop parallel to the ground, the front bumper must be exposed outside of the body.
11. A minimum of 1" diameter tubing and/or pipe is required for towing of the vehicle.
12. The rear bumpers must be constructed of tubing and/or flat stock. All rear bumpers and/or tubing utilized in the fabrication of the rear bumper assembly must have an end cap. The rear bumpers must protect the fuel cell.
13. The front and rear bumper(s) when measured from their center(s) must have a minimum of 25" of ground clearance; there will be a 2" tolerance, plus or minus, regarding this dimension. The rear bumper and/or the nerf bars must not extend beyond the width of rear tires. All bumpers must have round edges; sharp edges on any bumper and/or bumper surface will not be permitted.
14. The brace bars forward of the roll cage must not extend higher than stock hood height.
15. The rear push bars must not extend beyond 6" of the rear quarter panel(s).
16. All side bars and bumpers must be capped on ends.
17. The maximum overall width of the car, front and/or rear, shall not exceed 78" when measured from the outside of the tire tread on both sides of the vehicle. A maximum 1" spacer between the hub and wheel will be permitted. Steel or aluminum spacers will be permitted provided the overall tread width of the vehicle does not exceed 78".

ROLL CAGE

1. All cars must have a roll cage. The roll cage must be approved prior to competition and it must be welded to the frame. The driver's head must not protrude above the top of the roll cage with the driver's helmet on.
2. The top of the roll cage must extend above the top of the driver's helmet by a minimum of one 1". The entire roll cage and all roll bar pieces must be fabricated from magnetic steel a minimum of .095" in thickness.
3. The driver side and right-side door bars must be parallel to the ground and located perpendicular to the driver. A minimum of 3 door bars are required on the driver side and there must be right side door bars. The side bars

must be welded to the front and rear of the roll cage; no brazing or soldering permitted. The door bars must have a minimum thickness of .095" and must have a minimum of 1-1/2" diameter.

4. Foot protection is mandatory. One piece of magnetic steel tubing, a minimum .095" in thickness, must be fastened and/or welded across the back of the engine with vertical tubing a minimum of .095" thick.
5. The door side roll bars are mandatory and must extend into the door panels.
6. The roll cage must consist of continuous hoops that are no less than 1-1/2" in diameter and must have a minimum thickness of .095".
7. The roll cage must be mounted and securely welded to the frame in a minimum of 6 places.
8. The roll cage must consist of a configuration of front and rear hoops connected by tubing on the sides and/or side hoops. Roll cage must be securely supported and braced. Gussets to brace any portion of the roll cage will be permitted.

FRONT SUSPENSION: Steel aftermarket parts may be used as stock components. This includes lower tubular A-frames. Extended lower A-frames on right front only. Stock passenger car spindles or three (3)-piece spindle allowed. No tubular or fabricated spindles allowed. Tubular type upper and lower A-frames permitted. Lower control arms cannot be moved, (exception: may weld shock mount on lower control arm). Upper A-frames may be moved and have aluminum cross shafts. Coil springs minimum 4-1/2" diameter only (no coil overs) and must be mounted in stock position. No coil-over eliminators may be used. (Mono balls will be accepted.)

STEERING: Front steer type frames must have steering box mounted on left frame rail ahead of front cross member. Rear steer frames must have steering box mounted behind cross member on left frame rail. Power steering with a steering quickener is permitted. No rack and pinion steering. Stock type steering boxes only. All steering linkage must be steel components. Only one (1) power steering pump allowed. It is required that all cars have a collapsible steering shaft. All cars must be equipped with a quick-release-type steering wheel that is a full circle. Electronic steering or electronic steering components will not be permitted.

REAR END: Any passenger car or truck type rear end permitted. Quick change allowed with steel tubes (NO SLIP TYPE DIFFERENTIALS). NO ALUMINUM tubes with STEEL sleeves.

REAR SUSPENSION: May be coil spring (minimum 5") diameter or steel leaf springs. Coil-over eliminators or steel/aluminum coil-over kits may be used with coil springs. Lowering blocks (aluminum or steel) may be used with leaf springs. No aluminum birdcages, brake floaters or trailing arm mounts allowed. Panhard bar, panhard brackets and trailing arms may be steel or aluminum. One (1) spring per wheel.

Radius rods must be attached to the frame brackets and to the birdcages using metal spherical rod ends or mono ball type bearings. Non-metallic bearings and/or bushings will not be permitted. All mounting holes for attaching radius rods must be round and properly fit fastener being used to prevent movement.

Swing arm and/or Z-Link suspension are permitted. The shock on the swing arm or z-link rear suspension must be mounted to the bird cage or bottom rod. Top and bottom solid rod links must be mounted on heims and run in the opposite direction of bird cage.

WEIGHT: All GM 604 cars must weigh 2400 lbs and GM 602 cars 2250 lbs with the driver after the race at speedway scales.

The scales designated for the event will be considered the official scales for the event. Any car that is found light at the scales following qualifying/time trials will lose its time and start from the rear of a heat. Any car that is light at the scales following a heat race, B main/consy, or feature will be disqualified from the event.

Weight must be painted white and have car number on it.

Weights up to 50 lbs. must be securely fastened with a minimum of **two** (2) 1/2-inch, minimum grade 5 bolts with a minimum of two (2) weight clamps. Bolts must completely pass through each weight and the car. Threaded rods will not be permitted.

All added weight must be securely fastened to the frame below the body decking and windows.

Frame is defined as the welded steel structure only. Any part that moves or is not a fixed component to the steel frame structure may not be utilized for any weight attachment.

Weight(s) attached to the rear bumper, outside of the frame, and/or outside of the body of the car will not be permitted.,

Any car that loses any weight/ballast during an event may be subject to a penalty.

DRIVESHAFT: Must have a protection loop completely around. Loop must be .25" thick x 2" wide steel minimum and mounted no more than 6" back from U-joint in driveshaft. Drive shaft must be steel or carbon fiber.

TRANSMISSION: Must have forward and reverse gears and be able to shift to forward or reverse with engine running. Bert and Brinn type transmissions are permitted. Stock clutch type transmissions must have scattershield or blow proof bell housing. Automatics must be stock OEM cases and bell housings.

RADIATORS: May be aluminum, steel, or brass and must fit under hood line and be located in front of engine fan.

FAN: Engine must be equipped with a mechanical fan. No electric fan.

WATER PUMP: Cast or aluminum permitted. No electric water pump.

BRAKES: Must have brakes on all 4 wheels. Brake shut offs are permitted. Calipers may be steel or aluminum single piston OEM style only, steel rotors only.

A. GENERAL BODY:

- a. Bodies must follow the dimensions and appearance as shown in the body diagram at end of rules; the body must be symmetrical, including but not limited to doors, nose, sail panels, spoiler supports, etc.
- b. The front windshield and rear window supports must be stock appearing. The front window supports may have a clear Lexan support of no more than 16" inches including the roof post at the bottom and going straight to the roof. The support must be securely fastened in a positive manner.
- c. The sides of the engine compartment must remain open; side panels in the engine compartment area are not be permitted. A 5" maximum drop of the hood on either side of the hood will be permitted and it must be enclosed at the rear of the hood.
- d. One stone shield deflector measuring 18" x 18" mounted from the upper right frame rail to the lower right frame rail to protect rear mounted fuel/powering steering pumps will be permitted. The shield/deflector may be made of steel, aluminum, or heavy gauge wire.
- e. A minimum of 2" of tire clearance from the body is required.
- f. The minimum ground clearance for the frame/body will be 4".
- g. The maximum body width at the body's widest part will be 72". The minimum of width at the body's narrowest part will be 53". The top of the doors may have a maximum width of 67". The bottom of the doors may have a maximum width of 68".
- h. The left side rear door may flare out 6" for tire clearance; the bottom of the flare must be curved and rounded and not pointed in any fashion.
- i. The maximum rear width of the car must be 67" at the widest point.

B. NOSE:

- a. A maximum of a 1" flange on the outside edges, left and right side vertically, only for the purpose of strengthening, will be permitted on the front nose. Side fins and/or flanges of any kind along the length of the entire car, including hood, front, roof, will not be permitted.
- b. The nose piece must not exceed 45" inches in width and be centered between the frame rails. The nose piece must not extend past the leading edge of the front bumper and have a minimum of 6" from the ground to the bottom edge of the nose piece.
- c. The MD3 D3 Modified Aero Valance is approved.
- d. Nose must be level and flat from side to side.
- e. *Composite/plastic nose filler panel will be permitted.*

C. ROOF, ROOF POSTS, ROOF SUPPORTS & WINDOW SIDE PANELS:

- a. Roofs must be full size and symmetrical; half-moon roofs will not be permitted. The rear edge of the roof may not be mounted more than 12" past the rear axle.
- b. Wings, roof spoilers or ground effects of any kind will not be permitted.
- c. Maximum of 5 fasteners on the rear of the roof will be permitted.
- d. All flat type roofs will be allowed a maximum 3" difference in height between the front of the roof and the rear of the roof. This measurement may be taken from the interior and/or the ground. The rear of the roof must maintain the same height from side to-side.
- e. All front roof posts must meet the edge of the body.
- f. All rear roof posts must meet the edge of the body. All rear roof posts must be flat and straight with a 1" inch tolerance, no radius will be permitted.
- g. All curved type roofs will be allowed a maximum of 5" in the front and 2" inches in the rear. The break in the roof must be within 6" from the center of the roof.
- h. Wedge roofs will not be permitted.
- i. Dished roofs will not be permitted. Roofs must be rounded side-to-side. Bead rolls will be permitted. The roof must be level from side to side with a 1" wide x 1/8" thick stiffener in the center.
- j. The rear roof post must begin where it meets the back edge of the roof; the rear roof supports may not extend past the front side of the rear upright of the roll cage.
- k. The side vents on the front roof posts may extend rearward from the lowest point, a maximum of 16"-inches, then at a 90-degree angle to roof for one configuration, side vents must meet the outside of the car.
- l. The roof side (sail) panel window size must be 10" x 15" and must match drawing number 2- side view. The roof side (sail) panels must be the same design, length (top and bottom) on both sides of the car.
- m. Sail panels should measure no more than 17" tall with a 1" tolerance by 62" long and must meet the edge of the body. Both right and left side sail panels must measure exactly the same. No bow in the sail panel of any kind will be permitted. Sail panels must be straight with no curves allowed. Sail panels must measure a maximum of 3" at the rear of the deck.
- n. When using the long roof side (sail) panels they must be mounted in the same way as described above.
- o. If the long roof side (sail) panel is being used a 3" radius will be permitted.
- p. Any sun shield must be on a hinge for easy exiting; taping will not be permitted. The window opening must remain at a minimum of 12".
- q. All race cars in competition must meet the measurements illustrated in the RUSH car drawing.

- r. The roof should be single thickness of material. The roll bar hoops must be exposed for inspection.
- s. If the roof is curved, then a level will be placed on the top of the car and if the roof is 5" or less in the front and 2" or less in the rear and the break is in the middle then the roof will be permitted.
- t. Roofs must be stock appearing and must maintain the same height on both sides. If a RUSH or track official determines the roof does not meet the requirements as stated above, then a penalty determined by the official(s) may be determined prior to competition. Additional weight and/or other penalties may be assessed if the roof can be not meet the parameters stated above prior to competition in the event that the roof was inspected for.
- u. The minimum roof height is 42"with a maximum height of 54".
- v. The maximum roof width will be 50" with a minimum of 44". The roof must be level from side to side with a 1" wide x 1/8" thick stiffener in the center.
- w. The maximum roof length will be 56"with a minimum roof length of 41". A maximum of 5 fasteners on the rear of the roof will be permitted.
- x. The front roof post must be in a straight line from top to bottom; they must be the same on both sides.
- y. The maximum height on the rear roof post/sail panel vertical is 3".

D. DOORS:

- a. Composite/plastic right side door panel and right side quarter panel will be permitted. *Composite/plastic left side door panel and left side quarter NOT PERMITTED.*
- b. The top of the doors must remain in line with the rear engine plate. The bottom of the doors may extend a maximum of 8" past the motor plate toward the front of the vehicle. Any material that exceeds 8" forward of the engine plate will not be permitted.
- c. Right panel from top of door to bottom of door may not be no more than 3" and must be mounted straight inside the bottom.

E. DECK:

- a. The minimum deck height is 28" with a maximum height of 39".
- b. The deck height should measure within 1" from side-to-side.
- c. The measurement from the center of the hub to the rear top of deck will be a minimum of 34" and a maximum of 48".
- d. Interior decks must be flat from side to side.
- e. Option 1 – Interior decks must be flat from side to side. Interior decks may have up to a total of 6" of "rake" from the most forward part of the deck to the most rearward part of the deck as described below. Interior deck from the rear of the seat forward may be flat or have up to 3" of rake. The interior deck from the rear of the seat to the rear of the car cannot exceed 3" of rake regardless of how much rake the front portion measures. The rake of the rear portion of the interior deck must be in a straight flat line from the rear of the seat to the rear of the car. If using this option you will not be allowed a spoiler.
- f. Option 2 – Interior decks may have up to a total of 3" of rake from front to back and must be flat side to side. If you are using this deck option, then you will be allowed a 3" spoiler. The spoiler shall be a maximum of 3" tall. Any spoiler angle will be permitted. Three spoiler supports may be used; this includes side spoilers. The spoiler supports and side spoilers shall be 3" tall in the back and 2" tall in the front with a maximum total length of 12" at the bottom. The spoiler may be fabricated from lexan or aluminum.
- g. Interiors & deck must be made of aluminum
- h. Spoiler must be the same height all the way across the car.

F. INTERIOR & DRIVER COMPARTMENT:

- a. All windows must have a minimum 11" vertical opening. The entire interior must have a minimum of 11" of clearance from the interior deck to the roof and all sections of the roll cage. The interior deck sheet metal to the right side of the driver from the back of the seat forward should be fabricated on an angle from the driveshaft tunnel to the right-side window to promote ease of exit for the driver through the right side and or front window opening.
- b. Hydraulic and/or pneumatic weight jacks, trackers, or similar adjustable components of any type will not be permitted.
- c. Mirrors of any type will not be permitted.
- d. The driver's compartment must be sealed from the engine and the racetrack. The rear bubble of the hood should be closed and sealed from the driver.

G. BODY SKEW:

- a. The measurement of the left rear quarter panel from the center of the hub to the rear of the quarter panel should not exceed 48". Measuring 67" from the left rear quarter panel to the right rear quarter panel, when 90 1/2" forward along the right-side door, the diagonal measurement from that point to the top of the left rear quarter panel should not be less than 109 1/2"; you will be permitted a 1" tolerance.

H. DRIP RAIL

- a. Drip Rail can measure no more than 3".

EXOTIC MATERIALS: All exotic materials are illegal, which includes titanium, tungsten and/or carbon fiber.

EXCEPTION: carbon fiber driveshafts will be permitted for safety purposes as well carbon fiber fan blades and carbon fiber seats provided they meet the 39.2 specifications. Magnesium rear end center section, bells, and rear cover will be permitted. No other magnesium parts will be permitted.

MISCELLANEOUS: No radios (transmitting or listening devices) or mirrors permitted. Mirrored finished stainless or other materials are not permitted, if used for the same purpose as a mirror. No car will qualify without inspector approval. All cars must be available for inspection prior to advertised time of driver's meeting. All race cars are subject to inspection by officials at any time.

TRACTION CONTROL/RADIO/TRANSMISSION DEVICES:

1. All Traction Control Devices are strictly prohibited during any form or portion of a RUSH Series sanctioned event, race or practice/test session.
2. All traction control devices, whether electronically controlled in the ignition system, wheel sensors or any means of measuring ground speed to control wheel spin, are strictly prohibited. All devices not mentioned in the above that are found to control wheel spin, timing or fuel delivery control will be considered strictly prohibited.
3. At NO time will there be any type of ping control devices, remote devices that modify RPM and/or timing, automated throttle controls, timing controls, or any modifications to the ignition control boxes, distributors, or any other part of the Ignition System. This includes any add on component or components inside or outside the cockpit of any competitor's race car. There shall be NO driver controlled wheel spin, timing or fuel delivery control devices in the cockpit area of any race car. Remote control components utilized to affect and/or control wheel spin, timing or fuel will not be permitted.
4. Adjustable restrictor plates will not be permitted.

5. Radios and/or devices transmitting voice and/or data will not be permitted.
6. Data acquisition systems will not be permitted.
7. A competitor found with any of the devices mentioned under Traction Control/Radio/Transmission Devices, #1-6, will be disqualified from the event (loss of points and monies), forfeit the device permanently and the following:
 - First Offense: \$500 fine & 30-day suspension from any RUSH-sanctioned event plus any testing costs, if required
 - Second Offense: \$1,000 fine & 90-day suspension from any RUSH-sanctioned event plus any testing costs, if required
 - Third Offense: \$2,000 fine & 365-day suspension from any RUSH-sanctioned event plus any testing costs, if required
8. A competitor refusing to relinquish any of the above mentioned will result in disqualification from the event (loss of points and monies) and "refusal of tech" penalties.
9. GPS and/or any other type of electronic tracking and/or locating device will not be permitted for any reason. If found, driver and car will be disqualified for the night (loss of points and monies), and will forfeit device permanently.
10. GoPro and/or similar camera devices are permitted providing they do not interface with the car, electronic or otherwise, and do not transmit any signals. Cameras not meeting specifications, will result in driver and car being disqualified for the night (loss of points and monies), and will forfeit device permanently.
11. No cameras and/or video recorders and/or photographic recording equipment may be mounted below the deck. If found, driver and car will be disqualified for the night (loss of points and monies), and will forfeit device permanently. Note: RUSH reserves the right to mount recording equipment below deck, with driver's permission. near rear bumper facing outward towards oncoming competitors for promotional purposes.
12. Antennas will not be permitted in and/or attached to the race vehicle or carried by the driver. If found, driver and car will be disqualified for the night (loss of points and monies), and will forfeit antenna permanently.

DRIVER RADIOS/TRANSPONDERS:

All drivers are required to have a one-way radio to be utilized for communication from Track and/or Series Officials. The one-way radio must be working and active prior to any 'on-track' activity. Two-way radios, crew-member to driver and/or any other means of electronic communication, other than the one-way radio, will not be permitted.

Only approved transponders (lap timing and/or lap time recording devices) permitted (see each track's rules or RUSH Touring procedures for more info).

PERSONAL SAFETY EQUIPMENT:

General

1. Each competitor is solely responsible for the effectiveness and proper installation, per the manufacturer's specifications, of personal safety equipment and determining it to be adequate for competition at every event. Each competitor is expected to investigate and educate themselves for continuing improvement regarding their own personal safety equipment.
2. RUSH Rules regarding safety equipment are the minimum and you will not be permitted to compete if your safety equipment does not meet the RUSH rules. Many tracks and or states require additional safety equipment not mandated by RUSH. Be sure to familiarize yourself with the requirements of each track. RUSH-sanctioned tracks

and/or any track hosting a RUSH event will be required to enforce the RUSH safety rules completely without exception.

Protective Clothing

1. All drivers will be required to wear a fire resistant driving uniform meeting minimum of the SFI 3.2A/5 specification and display a valid SFI 3.2A/5 label on the outside of the uniform. Uniform must be worn at all times when driver is on the track including engine starts, practice, and competition.
2. Driver's gloves and shoes must meet or exceed the SFI 3.3 specification and have a legible and valid SFI 3.3 label. Drivers must wear gloves and shoes at all times when they are on track including practice and competition.
3. All drivers should wear fire resistant accessories including but not limited to; head sock, under garments, and socks at all times when they are on the track.

Full Containment Seats

1. Seats must be "Full Containment" style constructed of aluminum to the general design specifications of current industry standards, (SFI 39.2 highly recommended). Design shall include comprehensive head surround, shoulder and torso support system, energy impact foam, and removable head foam. Seats must be used as supplied and installed following instructions provided by the seat manufacturer. Consult with your seat manufacturer for questions and recommendations regarding your seat safety system.
2. Seats manufactured using carbon fiber or composite materials must meet SFI 39.2 specifications.
3. Up-fitting an existing seat with bolt-on kits will be permitted with a seat manufacturer-produced kit and an acceptable base seat approved by the seat manufacturer. Components must include comprehensive head surround, shoulder and torso support system, and energy impact foam. Consult with your seat manufacturer for recommendations regarding your current seat.
4. If the left head surround is 7"-inches or less when measured from the back of the headrest, then a left side head net meeting the SFI 37.1 must be installed with a quick release latch. A minimum left side head surround of 4"-inches is required.

Seat Belts/Restraint System

1. Each car will be equipped with minimum of an SFI 16.1 or SFI 16.5 approved restraint system. Restraint system will be eligible for use in competition until the expiration date or for two years from the date of manufacturer.
2. Seat belt restraint systems shall be installed and used in accordance with manufacturer's instructions.
3. In any type of manufacturer's installation the fasteners must be magnetic steel unless using type of mount in which the seat belt wraps around the roll cage. A seven-point harness is recommended.
4. Seat belt material should not be permitted to come in contact with any sharp or metal edge, including when the material passes through the seat.
5. Rolled and/or deburred and/or flanged edges or anywhere seat belt webbing passes through and may come in contact with abrasive edges are recommended.
6. Arm restraints are recommended and must be connected and used as instructed by the manufacturer.

Helmets/Head & Neck Restraints

1. All drivers must wear a full-face helmet with a minimum safety rating of FIA 8859-2015, FIA 8860-2018, Snell SA 2020, Snell EA 2016, Snell SA 2015.
2. It is strongly recommended that helmets should have the Eject™ helmet removal system installed as per the manufacturer's instructions.
3. At all times during an event including practice, qualifying and competition drivers MUST wear an SFI-approved head and neck restraint device/system that is properly mounted and connected per the manufacturer's instructions.
4. The head and neck restraint must be SFI 38.1 approved and display a legible and valid SFI 38.1 label.

Fire Suppression

1. A 10-lb fire suppression system meeting SFI 17.1 requirements is highly recommended.
2. Fire suppression systems must be used as supplied and installed following instructions provided by the fire suppression system manufacturer. Consult with your fire suppression system manufacturer for questions and recommendations regarding your fire suppression system.

Roll Bar Padding

1. SFI Spec 45.1 roll cage padding is mandated anywhere the driver's helmet may contact the roll cage while in the driving position. Other cockpit padding, knee, and steering pads, etc. recommended.

Other RECOMMENDED

1. Sharp and/or protruding edges in and around the cockpit will not be permitted.
2. Windshield screens should be a minimum thickness of 0.090 inch and should be securely fastened to the roll cage.
3. A clearly marked electrical engine shut off switch within the reach of the driver is permitted in addition to the "mandated" electrical engine shut-off that must be installed on the rear deck behind the driver's seat; see Battery/Starter section, #5 .
4. Driveline U-Joint scatter shields are recommended.
5. It is highly recommended cars be equipped with 10-lb fire suppression system meeting SFI 17.1 requirements.
6. A fire extinguisher in the rear of team's transporter is highly recommended. Fire extinguisher should be a minimum of 20lbs and is recommended to be FFF type chemical and/or Dupont FE-36 and/or equivalent.

GENERAL CAR INSPECTION:

All cars may be subject to technical inspection at any time. Any driver that fails to cooperate and/or allow an inspection of his car at any time will be subject to disqualification, a 45-day suspension, and \$750 fine. Note: In the event a part(s) must be removed for inspection, part(s) must be removed immediately by person(s) appointed by driver and/or car owner.

Full or partial car covers will be permitted only when there is inclement weather.

Rear car covers are permitted, but must be removed prior to leaving pit stalls. No covers of any kind under the car or covering wheel openings. Each team will receive one (1) verbal warning for the season. A second infraction will result in a loss of warm-ups, a loss of a qualifying lap, or placement to the tail of your next scheduled event, depending upon when said second infraction occurs.

FINES, PENALTIES, SUSPENSIONS & APPEALS

PRE-RACE TECHNICAL VIOLATION:

If a technical violation(s) is found during pre-race technical inspection, the driver/team will be advised of the violation and must meet full compliance before being allowed to compete.

REFUSAL OF TECH

A refusal of tech and/or failure to allow an official to confiscate a part(s), other than the already previously stated individual refusal penalties/suspensions, will result in a 45-day suspension and \$750 fine. All illegal parts will be confiscated.

MULTIPLE INFRACTIONS:

In the event driver and/or car is disqualified in post-race tech for the same technical rules infraction twice (excluding engines within the sealing system, tires, fuel, and shocks, springs, suspensions rules- see each rule for specific penalties), driver and car will be suspended for 7 days from all RUSH-sanctioned events. Each successive infraction will carry an additional 7-day suspension.

In the event an entrant fails technical inspection for multiple infractions that each carry a suspension and/or fine at the same event, suspension and/or fine will compound and accumulate with each infraction.

FINES & PENALTIES:

If an entrant is disqualified for any reason, any fine and /or suspension applies to both the driver and car owner if not the same person. In other words, if an entrant is disqualified for a technical violation, such as an engine not in compliance with tech specs, neither the owner nor the driver can compete for the suspension period, and while only one fine will be charged, neither party can race until that fine is paid. Fine must be paid in full to Series by cash or certified check in order to compete once suspension period ends. NOTE: If suspension includes 'a number of days' clause and occurs at the end of the season when no additional events exist, suspension will carry over to the following year beginning with the first RUSH-sanctioned event in the region.

EVENT SUSPENSIONS:

Owner suspended for any infraction will carry over to **ALL** RUSH-sanctioned divisions and will preclude owner from competing at **ANY** RUSH-sanctioned event until suspension is lifted. Driver suspended for any infraction will carry over to **ALL** RUSH-sanctioned divisions *unless* driver competes for a different car owner in other division(s). RUSH reserves the right to make judgment on a case-by-case basis and will have final say on eligibility to compete.

SPEEDWAYS CONTRACTING RUSH TO UTILIZE RUSH ENGINE SEALING SYSTEM:

In the event an engine infraction occurs at a speedway that has contracted RUSH to *only* utilize the RUSH Engine Sealing System, imposed fines, penalties, suspensions, etc. *may* carry over to RUSH-sanctioned competition for driver and car owner. Contact RUSH for listing of speedways, which *only* utilizes the RUSH Engine Sealing System.

LEGALITY OF PARTS:

If RUSH or Track Tech Inspector is unsure of the legality of a part, said part will be sent to GM or to RUSH Office for inspection. At this time, finishing position will be frozen until legality of said part is determined. In the event of a disqualification, finishing position, points and monies would be adjusted accordingly. **ALL ILLEGAL PARTS WILL BE CONFISCATED & DESTROYED!** Not allowing confiscating of parts is considered "cheating within the bolts" and said penalties will be imposed.

FINALITY OF DECISIONS AND INTERPRETATIONS AND COVENANT NOT TO SUE:

The decisions of RUSH officials or promoter at an event, including the interpretation and application of rules and the scoring of positions, shall be FINAL, BINDING, and NON-APPEALABLE, except in the case of a suspension or fine, which is further explained in the SUSPENSIONS/FINES & APPEALS category.

All participants, as a condition of participating in an event, agree that ALL decisions of officials or the promoter, regarding the interpretation and application of the rules, and the scoring of positions, shall be NON-LITIGABLE. All participants further covenant and agree that they will NOT initiate any of legal action against Great Crate Racing Northeast D/B/A RUSH Racing Series, the promoter, and officials to challenge such decision, to seek monetary damages, to seek injunctive relief, or to seek any kind of legal remedy. If a participant pursues any such legal action, which violates this provision, then the participant and/or owner expressly agrees to reimburse RUSH for ALL of its ATTORNEY FEES and COSTS IN DEFENDING AGAINST SUCH LEGAL ACTION.

By signing the annual registration agreement, *or by participating in an event conducted under rules promulgated by or sanctioned by RUSH*, competitors agree that they will comply with all written rules and procedures of RUSH. In the event of a breach of any agreement or rules, competitor shall be liable for actual and liquidated damages sustained by RUSH Racing Series.

APPEALS PROCESS:

RUSH will determine any and all suspensions/fines that are covered in the rules and any violation that may come up during the year. RUSH will make judgment on the sanctions, and violator(s) will be sent official notice by a certified letter, return receipt requested.

Driver and/or car owner has the opportunity to appeal his or her sanction and must do so in writing accompanied by any relevant documentation. Appeal must be in writing and e-mailed to the RUSH Office at info@rushracingseries.com within 48 hours of notification of violation.

RUSH will then set a date and time for the appeal hearing at the business office located at the address of 4368 Route 422, Pulaski, PA 16143. The violator(s) will present his/her case to the RUSH Racing Series. The violator(s) and one other person is permitted to attend the appeal hearing. Additional attendees must be approved by RUSH pursuant to a written request.

Following the appeal hearing with the violator(s), RUSH may conduct further follow-ups, meetings, etc. with any other necessary party(s). Judgment will then be rendered to the violator by a certified letter, return receipt.

Violator(s) agrees that the decision made will be final and party posting appeal has no legal rights thereafter. In the event of a protest, the party that protested also agrees to accept final ruling on decision and has no legal rights thereafter.

MISREPRESENTATION

False or inaccurate statements or information provided to RUSH in any instance(s) will render it void, and will excuse RUSH from any obligation created herein. Further, RUSH reserves the right to seek compensation for any damage suffered as a result of its reasonable reliance on the information provided.

BODY DIAGRAM:

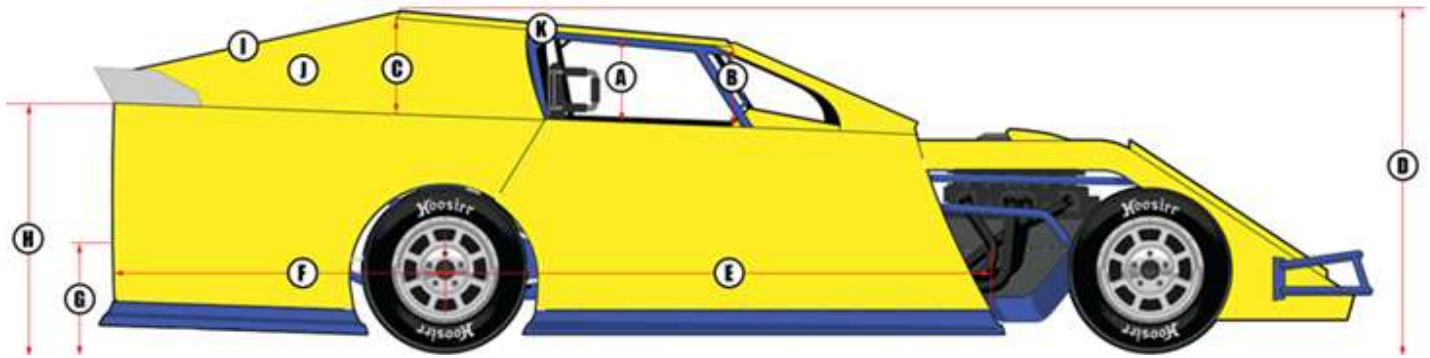

- A. Window opening: 11" min - 18" max
- B. Front edge of roof to interior deck: 11" min
- C. Rear edge of roof to interior deck: 12" min
- D. Highest point of roof to ground: 42" min - 52" min
- E. Center of rear wheel to front edge of door: 72" max
- F. Center of rear wheel to rear edge of quarter panel: 34" min - 47" max
- G. Center of lowest bar on rear bumper to ground: 16" min - 20" max
- H. Deck height to ground: 28" min - 39" max
- I. No bow permitted in the sail panel from the rear of roof to rear of sail panel.
- J. No bow permitted in the sail panel from the bottom of the sail panel to the roof.
- K. Drip edge: 3" max

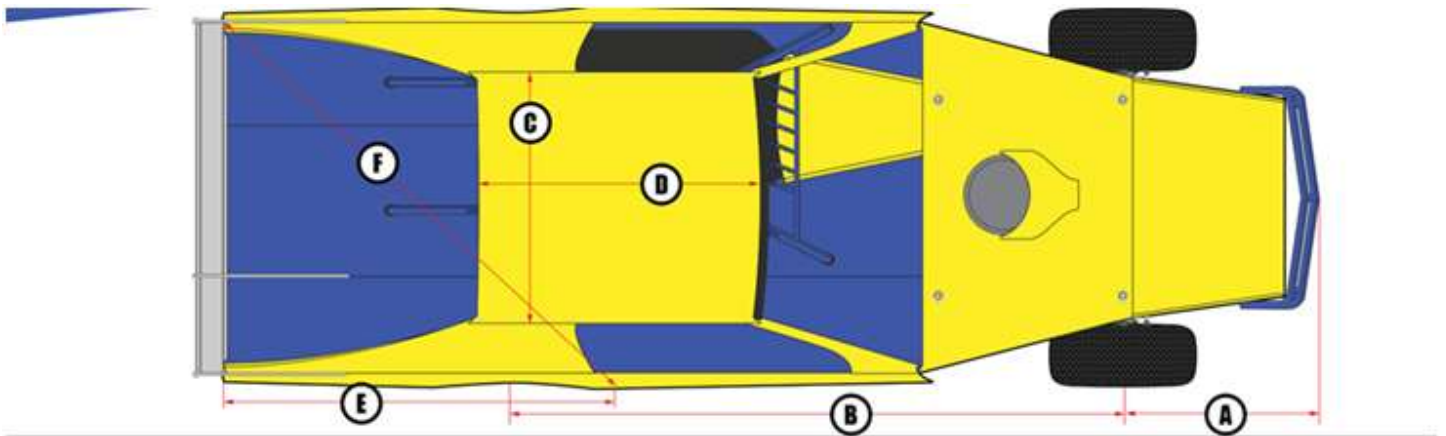

- A. Center of front wheel to front edge of front bumper: 42" max
- B. Wheelbase: 108" min - 112" max
- C. Roof width: 44" min - 50" max
- D. Roof length: 41" min - 56" max
- E. Reference point. Ninety and one-half inches (90.5") from rear deck bar
- F. Diagonal reference point. One-hundred thirteen inches (113") from left-rear spoiler to "E" reference point

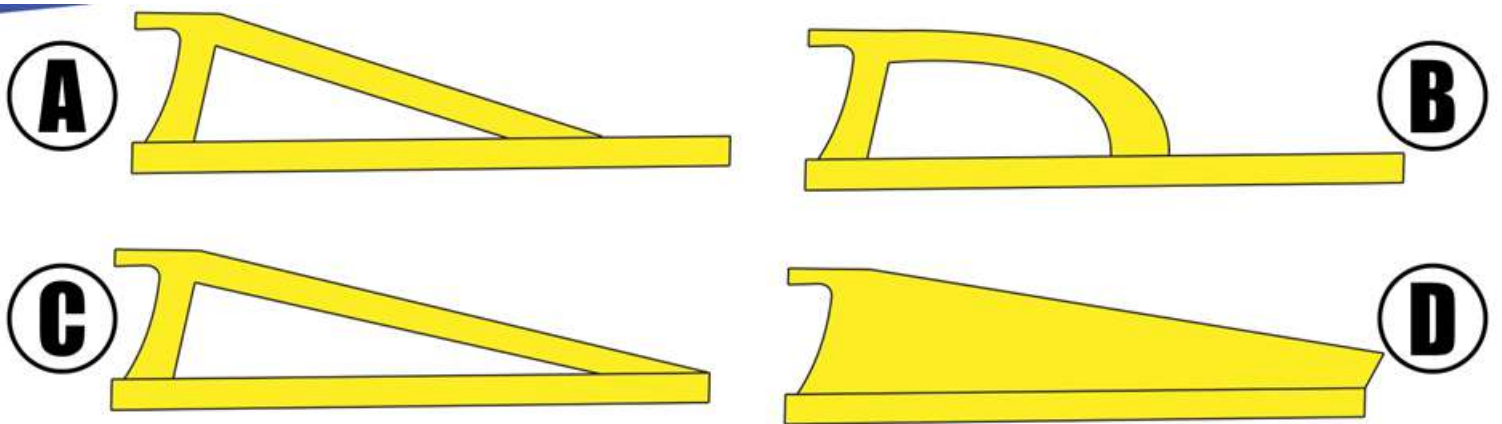
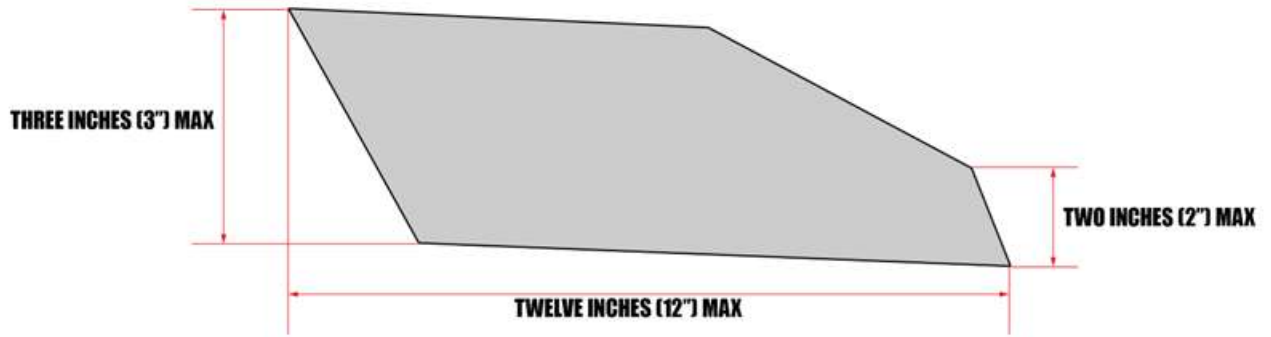

WINDOWS MUST BE THE SAME ON BOTH SIDES